



## Information:

### Solar container for photovoltaic power plant HSC550kW

The solar container is a new design for large solar power plants. The container includes the converter, medium voltage transformer and the medium voltage switchgear. The container is a plug and play solution for quick installation with low total costs. The container has an AC output power of 550 kW in a 20 ft high cube container.

The photovoltaic array is connected with the aid of fuses or circuit breaker and the EMC filter to the DC link of the converter. Optional can the current in each string (fuse) be measured. The total converter is build with two identical converter stages. Each converter can run independently from each other. The converters supply the energy in a special medium voltage transformer with two low voltage windings, optimized for the photovoltaic array. The medium voltage switchgear connects the container with the medium voltage grid. The auxiliary power supply for the converters and heating can be done with the aid of the transformer T2 (option) or from an external source. The converters include all control of the converter and the maximum power point tracker. The converter is supplied with an Ethernet. With the Ethernet connection all important information's can be downloaded and if a failure is detected a Email can be send.

The container is a complete factory mounted system only the DC connection of the photovoltaic array, AC connection of the medium voltage and the Ethernet communication must be connected in the power plant. Optional can the communication be done with the aid of a GSM modem.

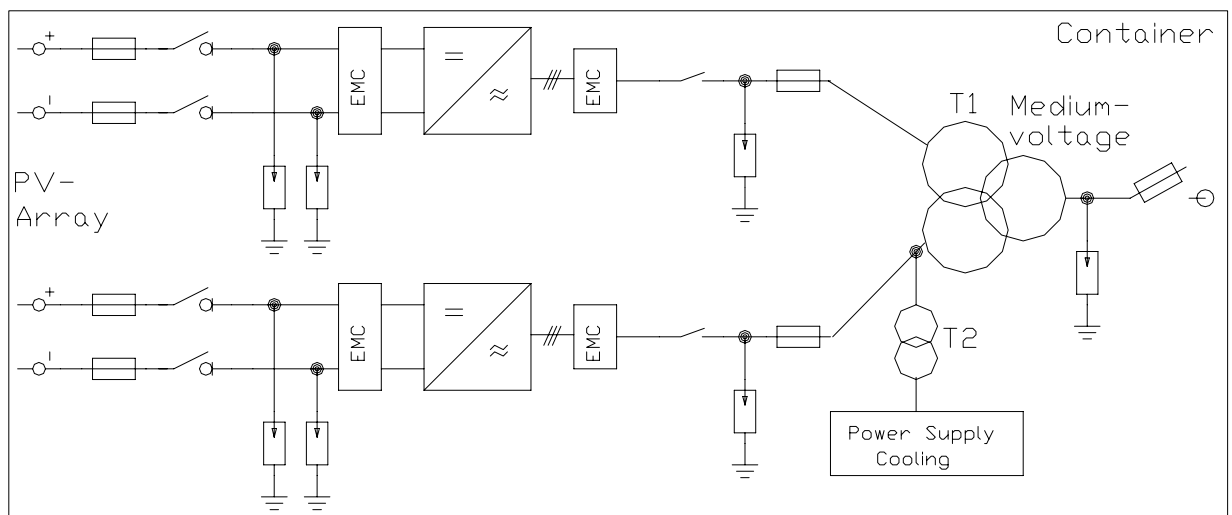



## Preliminary technical data:

### Electrical data:

Rated AC- power	: 550 kW	, with +/- 10 % grid voltage
Maximum AC-Power	: 605 kW	, with rated grid voltage
Rated grid voltage	: 20 kV	, other voltages on request
Maximum AC-current	: 17,5A	
Line power factor (cos φ)	: > 0.98	, at rated power
AC current distortion (THD)	: < 3 %	
Rated PV – power	: 567 kW	
Maximum PV- power	: 2 x 314 kW	, with rated grid voltage
Maximum PV – current	: 2 x 670 A	
Maximum PV no load voltage	: 900 VDC	
MPP-area for rated power	: 450 VDC – 820VDC	
Control strategy	: Maximum Power Point Tracking	
Efficiency (10,25,50,75,100)%	: (95,8/97,4/97,5/97,4/97,1) %	
EU – efficiency	: 97,1 %	, including transformer without auxilliary supply
EU – efficiency	: 96,9 %	, including transformer with auxilliary supply
Feed in at	: 800 W	
Losses Standby	: 80 W + 700 W	
Max. power aux. supply	: < 1000 W + heating (if necessary)	

### General data:

Ambient temperature	: -10 °C until 45°C	, lower value on request
Altitude	: up to 2000 m over sea level without de-rating	
Cooling	: Active air cooling	
Min. air quality EN60721-3-3	: Class 3S2	
Enclosure environmental rating	: IP54	
Dimension (H x W x D) [mm]	: 2895 x 6058 x 2438	
Weight	: < 15000 kg	
Colour of the container	: RAL7035	, other colour on request
Electro-Magnetic Interference	: EN61000-6-2, EN61000-6-4	
Grid quality requirements	: complies VDEW requirements	
CE – conformity	: complies	

### Features:

Disconnecter DC	: Motor driven disconnecter
Display	: Touch screen with numeric and graphic display
Earth failure detection	: Insulation measuring instrument
Monitoring of surge arrester	: DC side

### Options:

DC-Fuses or DC circuit breaker for protect up to thirty DC branches.  
Monitor the DC branches currents with current sensors.